

# SEG-9SP3 SECURITY GRILLE – SUPPLY OR RETURN

Complies with NIC recommendations and California BoP Title 24

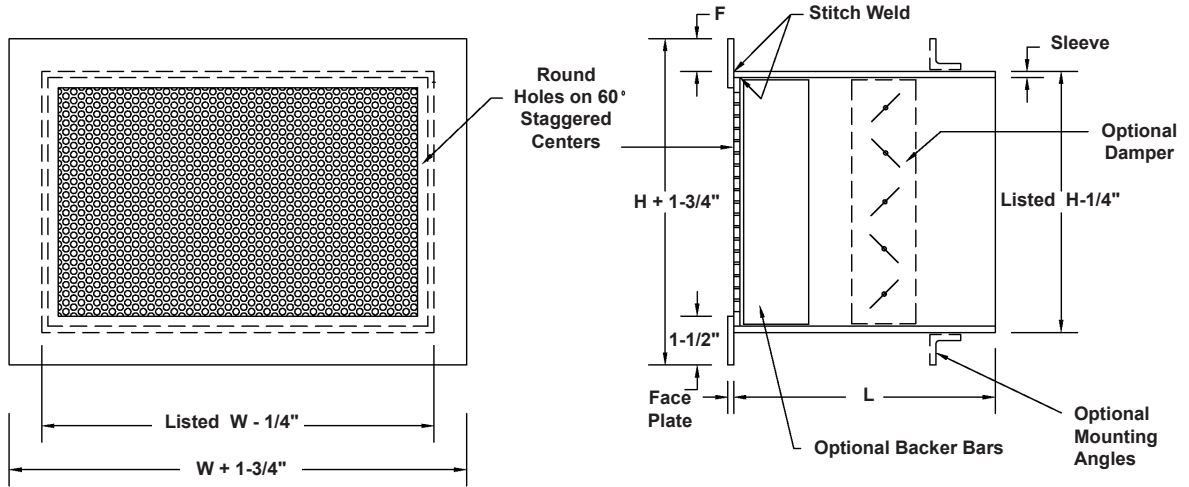

**STANDARD CONSTRUCTION**

**Flange:** 3/16" steel stitch welded to sleeve. 1" face flange.  
**Face:** 3/16" thick steel stitch welded to sleeve. 3/16" diameter holes on 9/32" staggered centers.  
**Sleeve:** 3/16" steel with continuously welded or formed seams.  
**Finish:** Two part polyurethane inside and out. White.

**REQUIRED CONSTRUCTION:**

- Flange Material:**  3/16" steel (Std.)  
 10 ga. steel  
 12 ga. steel  
 Other \_\_\_\_\_
- Face:**  .187" thick with 3/16" dia. holes on 9/32" centers. (Std.)  
 Other \_\_\_\_\_
- Flange "F":**  1" (Std.)  
 Other \_\_\_\_\_
- Sleeve Material:**  3/16" steel (Std.)  
 10 ga. steel  
 12 ga. steel  
 Other \_\_\_\_\_
- Finish:**  White (Std.)  
 Other \_\_\_\_\_
- Other Material:**  **SEG-9SP3A** all aluminum (Consult factory for material thickness)  
 **SEG-9SP3SS** all stainless steel (Consult factory for material thickness)

Sizes 18" x 18" and under may be constructed with a one piece face. See drawing No. SEG-9SP31

**MOUNTING OPTIONS:**

- 11A.** Two loose pieces of 1" x 1" x 3/16" mill finish steel angle loose for field welding to sleeve. Length equal to longest side of grille. Other angle size \_\_\_\_\_
- 11B.** Rear angle frame of 1" x 1" x 3/16" mill finish steel completely assembled for field welding to sleeve. Other angle size \_\_\_\_\_
- 12A.** Rear angle frame for bolting to sleeve. 1" x 1" x 3/16" steel with bolt holes 8" o.c. for 1/4" dia. bolts. No holes in sleeve. No bolts, nuts or washers. Other angle size \_\_\_\_\_
- 12B.** Same as **12A** with addition of bolt holes in sleeve. (Advise wall or ceiling thickness). Other angle size \_\_\_\_\_
- 23.** Masonry anchors: 1/2" x 3" Anchors 16" o.c., one per side minimum, welded to sleeve exterior. Other size or spacing \_\_\_\_\_
- 24.** Countersunk screw holes in face 10" o.c. with #10-24 x 2" long Torx security machine screws for 1-1/2" maximum ceiling thickness. 1" x 1" x 1/8" steel angle frame with matching holes and foldover nuts. Requires 1-1/2" flange.
- 25.** Countersunk screw holes in face 10" o.c. with #10 x 1-1/2" long Torx security sheet metal screws. Other screw length \_\_\_\_\_

**ACCESSORIES:**

- 16F.** Face operated opposed blade damper tack welded into sleeve. Dampers are adjusted using flat bladed screwdriver.
- 16R.** Rear operated opposed blade damper tack welded into sleeve. Dampers are adjusted using flat bladed screwdriver.
- 21.** 2" x 1/4" A-36 mild steel vertical backer bars 6" o.c.. Welded to sleeve tight to face.
- Other:** \_\_\_\_\_

Qty.	Listed Size		Sleeve O.D.		Masonry Opening		Sleeve Length L	Wall / Ceiling Thickness	Accessories	Mounting Option	Tag
	W	H	W	H	W	H					

To maintain KEES' policy of continuous product improvement, we reserve the right to change prices, specifications, ratings or dimensions without notice or obligation.

<b>Project</b>		<b>Location</b>				
<b>Architect / Engineer</b>						<p><b>KEES INCORPORATED</b>                  Elkhart Lake, WI 53020                  Phone: (920) 876-3391                  Fax: (920) 876-3065                  Website: www.kees.com</p>
<b>Contractor</b>	<b>Dwg. No.</b>	SEG-9SP3w 7/10/2012				
<b>Representative</b>	<b>Date</b>					