

SEG-13 RISK RESISTANT SECURITY GRILLE

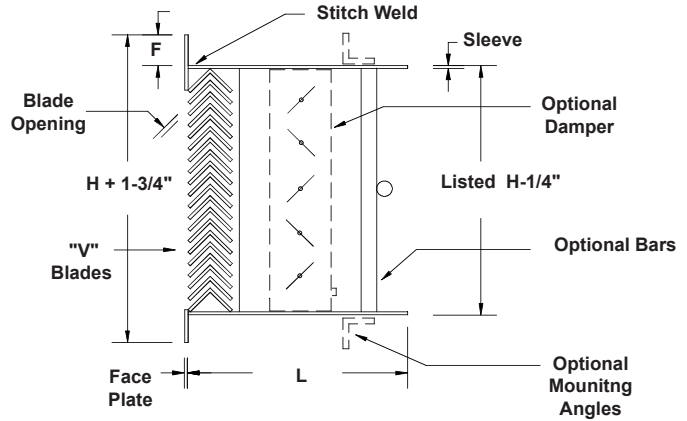
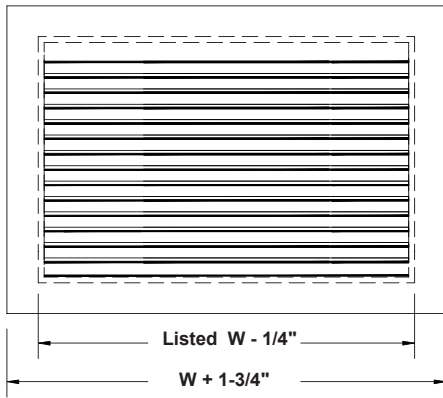

STANDARD CONSTRUCTION

Face: 12 ga. steel stitch welded to sleeve. 1" face flange.
Blades: 12 ga. steel "V" blades with 3/16" openings. Blades are welded to sleeve.
Sleeve: 12 ga. steel with continuously welded or formed seams.
Finish: Two part polyurethane inside and out. White.

REQUIRED CONSTRUCTION:

- Face Material:** 12 ga. steel (Std.)
 3/16" steel
 Other _____
- Blade Material:** 12 ga. steel (Std.)
 Other _____
- Blade Opening:** 3/16" (Std.)
 1/8"
 Other _____
- Flange "F":** 1" (Std.)
 Other _____
- Sleeve Material:** 12 ga. steel (Std.)
 3/16" steel
 Other _____
- Finish:** White (Std.)
 Other _____
- Other Material:** SEG-13A .100" aluminum construction
 SEG-13SS 12 ga. 304 stainless steel construction

MOUNTING OPTIONS:

- 11A.** Two loose pieces of 1" x 1" x 3/16" mill finish steel angle loose for field welding to sleeve. Length equal to longest side of grille. Other angle size _____
- 11B.** Rear angle frame of 1" x 1" x 3/16" mill finish steel completely assembled for field welding to sleeve. Other angle size _____
- 12A.** Rear angle frame for bolting to sleeve. 1" x 1" x 3/16" steel with bolt holes 8" o.c. for 1/4" dia. bolts. No holes in sleeve. No bolts, nuts or washers. Other angle size _____
- 12B.** Same as **12A** with the addition of bolt holes in sleeve. (Advise wall or ceiling thickness). Other angle size _____
- 23.** Masonry anchors: 1/2" x 3" Anchors 16" o.c., one per side minimum, welded to sleeve exterior. Other sizes or spacing _____
- 24.** Countersunk screw holes in face 10" o.c. with #10-24 x 2" long Torx security machine screws for 1-1/2" maximum ceiling thickness. 1" x 1" x 1/8" steel angle frame with matching holes and foldover nuts. Requires 1-1/2" flange.
- 25.** Countersunk screw holes in face 10" o.c. with #10 x 1-1/2" long Torx security sheet metal screws. Other screw length _____

ACCESSORIES:

- 16R.** Rear operated opposed blade damper tack welded into sleeve. Dampers are adjustable using flat bladed screwdriver.
- 19.** 1/2" dia. A-36 mild steel security bars 6" o.c. both ways, welded to sleeve and at intersections.
- Other:** _____

Qty.	Listed Size		Sleeve O.D.		Masonry Opening		Sleeve Length L	Wall / Ceiling Thickness	Accessories	Mounting Option	Tag
	W	H	W	H	W	H					

To maintain KEES' policy of continuous product improvement, we reserve the right to change prices, specifications, ratings or dimensions without notice or obligation.

Project		Location				
Architect / Engineer						
Contractor			Dwg. No.	SEG-13 06/29/17		
Representative			Date			

KEES

KEES INCORPORATED
 Elkhart Lake, WI 53020
 Phone: (920) 876-3391
 Fax: (920) 876-3065
 Website: www.kees.com