

SEG-9SP2TG SECURITY TRANSFER GRILLE

Complies with NIC recommendations and California BoP Title 24

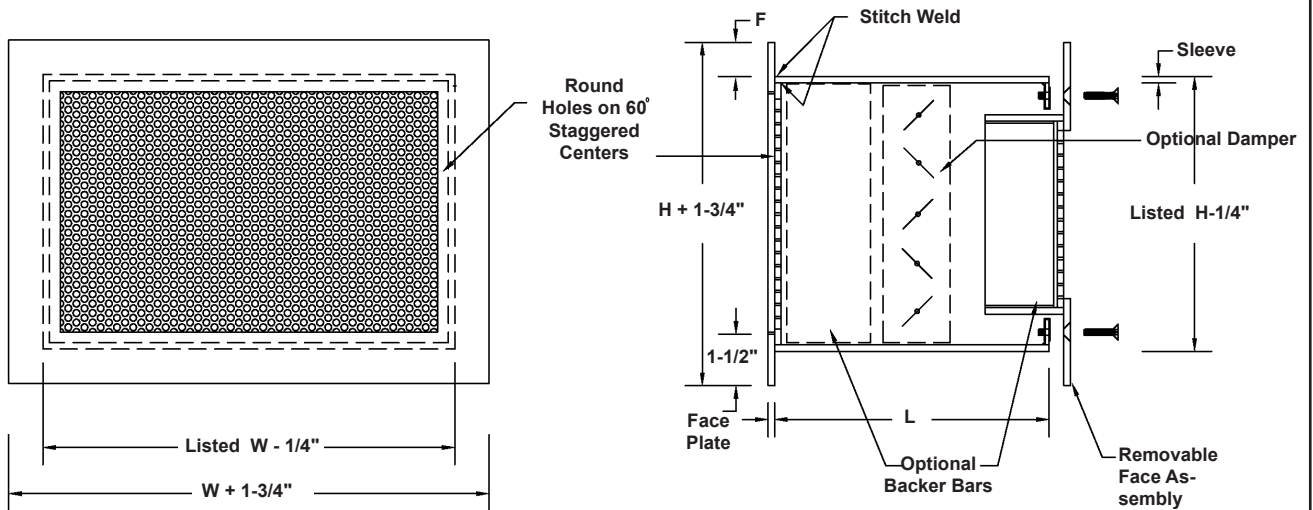

STANDARD CONSTRUCTION

Flange: 10 ga. steel stitch welded to sleeve. 1" face flange.
Face: .120" thick steel stitch welded to sleeve. 1/8" diameter holes on 3/16" staggered centers.
Sleeve: 10 ga. steel with continuously welded or formed seams.
Finish: Two part polyurethane inside and out. White.

REQUIRED CONSTRUCTION:

- Flange Material:** 10 ga. steel (Std.)
 3/16" steel
 12 ga. steel
 Other _____
- Face:** .120" thick with 1/8" dia. holes on 3/16" centers. (Std.)
 Other _____
- Flange "F":** 1" (Std.)
 Other _____
- Sleeve Material:** 10 ga. steel (Std.)
 3/16" steel
 12 ga. steel
 Other _____
- Finish:** White (Std.)
 Other _____

MOUNTING OPTIONS:

- 26.** Countersunk screw holes in removable face 10" o.c. with #10-24 x 1" long Torx security machine screws. Screws thread into foldover nuts on 10 ga. steel flange that is stitch welded to sleeve interior.

ACCESSORIES:

- 16F.** Opposed blade damper tack welded into sleeve. operable through fixed face. Requires 3/16" dia. hole for access to damper.
- 16R.** Opposed blade damper tack welded into sleeve, operable through removable face. Requires 3/16" dia. hole for access to damper.
- 21.** 2" x 1/4" hot rolled steel vertical backer bars 6" o.c., welded to sleeve.
- Other:** _____

Qty.	Listed Size		Sleeve O.D.		Masonry Opening		Sleeve Length L	Wall Thickness	Accessories	Mounting Option	Tag
	W	H	W	H	W	H					

To maintain KEES' policy of continuous product improvement, we reserve the right to change prices, specifications, ratings or dimensions without notice or obligation.

Project		Location	
Architect / Engineer			<p>KEES INCORPORATED 400 S. Industrial Dr. • P.O. Box L Elkhart Lake, WI 53020 Phone: (920) 876-3391 Fax: (920) 876-3065 Website: www.kees.com</p>
Contractor		Dwg. No. SEG-9SP2TG 07/18/04	
Representative		Date	